



IMPORTANT SAFETY INSTRUCTIONS

Please read this manual carefully and follow its instructions. Improper use or failure to follow these instructions could result in serious injury, property damage or death. Operators must be trained and instructed in the safe and proper use and maintenance of this product. Keep this manual for future reference.

The following signal words and meanings are intended to explain the levels of risk associated with this product.

	DANGER	Indicates a hazardous situation that, if not avoided, WILL result in serious injury or death
	WARNING	Indicates a hazardous situation that, if not avoided, COULD result in serious injury or death
	CAUTION	Indicates a hazardous situation that, if not avoided, MAY result in minor or moderate injury

INSTALLATION

MOUNTING

	CAUTION	READ INSTRUCTIONS BEFORE USE To avoid injury: all operators should be instructed in the safe, proper use and maintenance of this product.
---	----------------	--

- Hang retractor in desired location and secure unit by means of Clevis Pin and Safety Cotter Pin from provided shackle.
- Retractor should be suspended directly over work area, using an eyebolt or similar device with a break-strength exceeding 6 times the combined weight of retractor and load it is supporting. [See - Fig. 01]
- Unit should be mounted in such a manner as to minimize cable contact with cable guide to prolong cable assembly life. [See - Fig. 01]

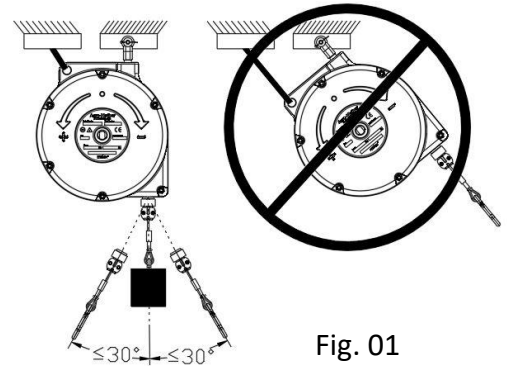



Fig. 01

SECONDARY SUPPORT

	WARNING	FALLING OBJECT HAZARD To avoid serious injury or death: All units mounted overhead must be secured by means of a safety cable or safety chain.
--	----------------	---

- A hole has been provided at top/side of housing to permit installation of a safety chain or safety cable onto unit.
- Other end of safety chain or safety cable is to be attached to a supporting component separate from the one already supporting the retractor itself. [See - Fig. 02]
- Safety chain or safety cable should be as short as possible, allowing reel to drop no more than 6 to 12 inches if the primary connection is released.
- Safety Cables are offered as an accessory item, contact factory for more details.

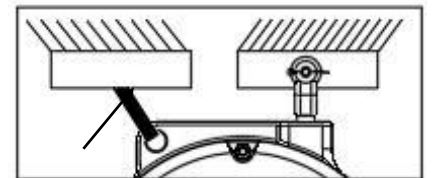

Fig. 02

OPERATION

TOOL ATTACHMENT

WARNING **CABLE CAN RETURN SUDDENLY** To avoid serious injury or death: Always **LIFT LOAD** to hook. Never pull cable to attach Load to be retracted. If hook is accidentally released while it is extended, it could snap back quickly.

- Always measure weight of total LOAD [tool complete with hoses, cables and fittings] to make sure it is within Weight Capacity of Retractor printed on unit label.
- Lift LOAD [See - Fig. 03] to retractor and attach it to the carabiner hook, making sure the spring-loaded latch of carabiner is fully closed. If carabiner comes with a Lock Nut, make sure to lock the latch in place by means of Lock Nut.
- Extension cables are available for lowering the position of the tool without reducing active travel. Contact factory for more details.

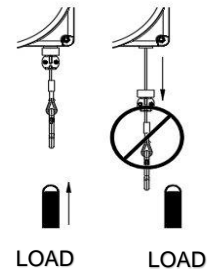

Fig. 03

UNIT POWER SPRING TENSION ADJUSTMENT

WARNING **CABLE CAN RETURN SUDDENLY** To avoid serious injury or death: Load **MUST** be fully attached to retractor before adjusting tension.

CAUTION **ROTATING PARTS AND FLYING OBJECTS** To avoid injury: Always increase or decrease tension slowly, with wrench held firmly on shaft flats.

- Before adjusting spring tension, make sure that the LOAD [including all attachments and connections] is properly attached to retractor.
- If load exceeds spring tension, tool will drop, and tension must be increased.
- If load rapidly retracts into unit, then spring tension is excessive; the tension should be decreased to ensure proper ergonomics.
- Tension should always be enough to retract tool until cable stop rests against the cable guide.

Unit Tension Adjustment

- To increase tension, engage a wrench on flats on mainspring shaft and turn in “+” direction. [See - Fig. 04]
- To decrease tension, engage a wrench on flats on mainspring shaft; then, while firmly holding the wrench in place, gently push the tension release lever on opposite side of retractor and control the tension by turning the firmly held wrench in minus “-” direction. [See - Fig. 05]
- After adjusting tension, pull cable to fullest extension to ensure full active cable travel. If cable does not reach full extension, some tension must be released. If proper tension and extension cannot be achieved, a different unit may be required. Please consult technical support group.

Fig. 04

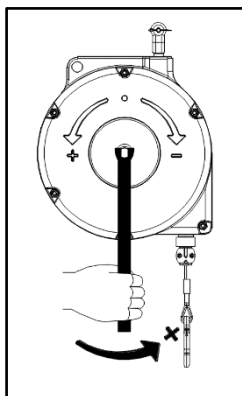
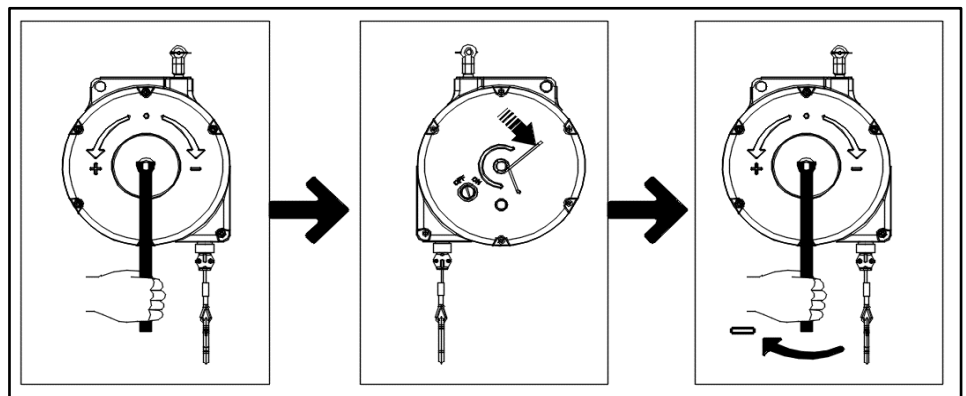

Fig. 05



CABLE STOP ADJUSTMENT

WARNING CABLE CAN RETURN SUDDENLY To avoid serious injury or death: Remove all tension on unit before adjusting the cable stop to increase overhang.

- Cable stop is adjustable and can be moved up along the cable, enabling a longer overhang distance to attain the most desirable working height. [See - Fig. 06]
- Please note that for each increase in overhang, the active travel is reduced by the same distance.
- **ALL TENSION MUST BE REMOVED FROM UNIT BEFORE ADJUSTING CABLE STOP. [See page 2 for directions on how to remove tension.]**
- Loosen screws on cable stop, then slide cable stop upward toward cable guide. When desired overhang is achieved, tighten cable stop back onto cable.
- If additional overhang is required, extension cable assemblies are offered as an accessory.

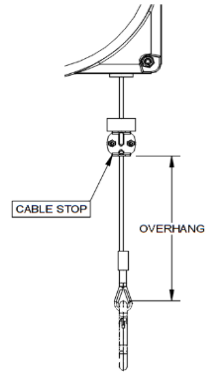

Fig. 06

RATCHET LOCK

Ratchet Engagement

- To engage ratchet, pull cable to desired location and then let cable slowly retract until lock engages.
- If no engagement, pull a little further, and let retract. [See - Fig. 07]
- Ratchet lock engages about every 9" (230mm) of travel. [See - Fig. 08]
- To release lock, pull out cable by at least 6" (160mm). [See - Fig. 09]

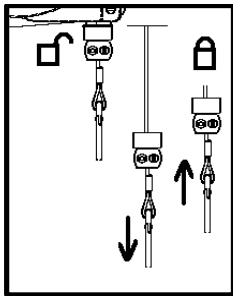

Fig. 07

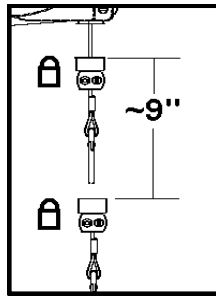

Fig. 08

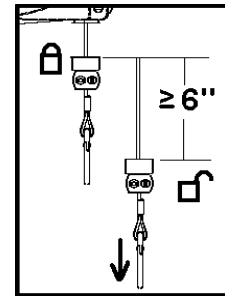

Fig. 09

Ratchet On/Off

- Unit comes with an ON/OFF Ratchet Lock selector.
- Turn slotted head selector to ON position to engage Ratchet Lock position or to OFF to disengage the Ratchet Lock. [See – Fig. 10]

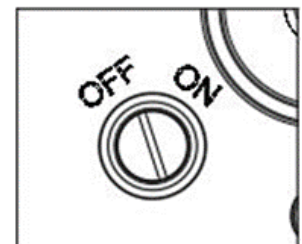

Fig. 10

SERVICE

 **CAUTION** **READ INSTRUCTIONS BEFORE SERVICING** To avoid injury: Only fully trained personnel should perform repairs on unit.

 **CAUTION** **READ INSTRUCTIONS BEFORE SERVICING** To avoid injury: Always remove unit from service before performing any repairs.

 **CAUTION** **READ INSTRUCTIONS BEFORE SERVICING** To avoid injury: Remove all spring tension from unit before performing any repairs.

LUBRICATION

The retractor is lifetime lubricated at the factory. No additional lubrication is necessary.

PREVENTIVE MAINTENANCE

Cable Assembly

- Check hook for wear. Any damage to hook requires replacement.
- Check cable stop and swage fitting next to hook for damage. Any damage indicates need for a new cable assembly.
- Check along entire length of cable for wear, breaks or fraying. If any damage, cable assembly must be replaced.

Upper Mount

- Check tightness of mounting bolts and/or soundness of mounting connection.
- Check mounting shackle for wear. Any damage to shackle requires replacement.
- Check condition of safety cable/chain and attachment points.

SPRING & DRUM CASSETTE REPLACEMENT

 **CAUTION** **READ INSTRUCTIONS BEFORE SERVICING** To avoid injury: Remove all spring tension from unit before performing any repairs.

 **CAUTION** **ROTATING PARTS AND FLYING OBJECTS** To avoid injury: Always increase or decrease tension slowly, with wrench held firmly on shaft flats.

 **WARNING** **HIGH SPRING TENSION** To avoid serious injury or death: Do not open Power Spring Cassette, which encloses the Power Spring. Power Spring is dangerous if not enclosed. To change Power Spring, send unit to an approved service center.

Spring & Drum Cassette Replacement Procedure:

1. Remove tension completely from unit, see page 2 for "UNIT POWER SPRING TENSION ADJUSTMENT."
2. Remove screws [Items 3 and 4] and nuts [Item 11].
3. Remove retaining ring [Item 9].
4. Open housing [Item 10] and remove upper mount [Item 18] and cable guide [Item 16] from housing.
5. Unwind cable assembly [Item 20] from spool, remove nut holding cable to drum and remove cable.
6. Remove retaining ring [Item 1], spring lever [Item 2] and housing retaining ring [Item 1] attached to Item 21.
7. Remove spring & drum assembly [Item 12] from unit. DO NOT OPEN the cassette to expose raw power spring.
8. Reassemble new spring & drum assembly [Item 12] in housing by reversing steps 6 and 5.
9. Reassemble unit by reversing steps 4, 3, 2 and 1 above.

CABLE REPLACEMENT

- Perform steps 1 to 5 from “SPRING & DRUM CASSETTE REPLACEMENT.”
- Install new cable, while making sure to thread new cable end through cable guide.
- Reassemble unit by reversing steps 4, 3, 2 and 1 above.

RATCHET LOCK REPLACEMENT

- Perform steps 1 to 7 from “SPRING & DRUM CASSETTE REPLACEMENT.”
- Remove Items 7 and 8 to be able to remove Item 6 from housing [Item 21].
- Replace Item 6 with a new repair part.
- Reassemble unit by reversing steps 7 to 1 above.

REPAIR PARTS – DIAGRAM

NOTE: When ordering repair parts, always include unit model number and serial number.

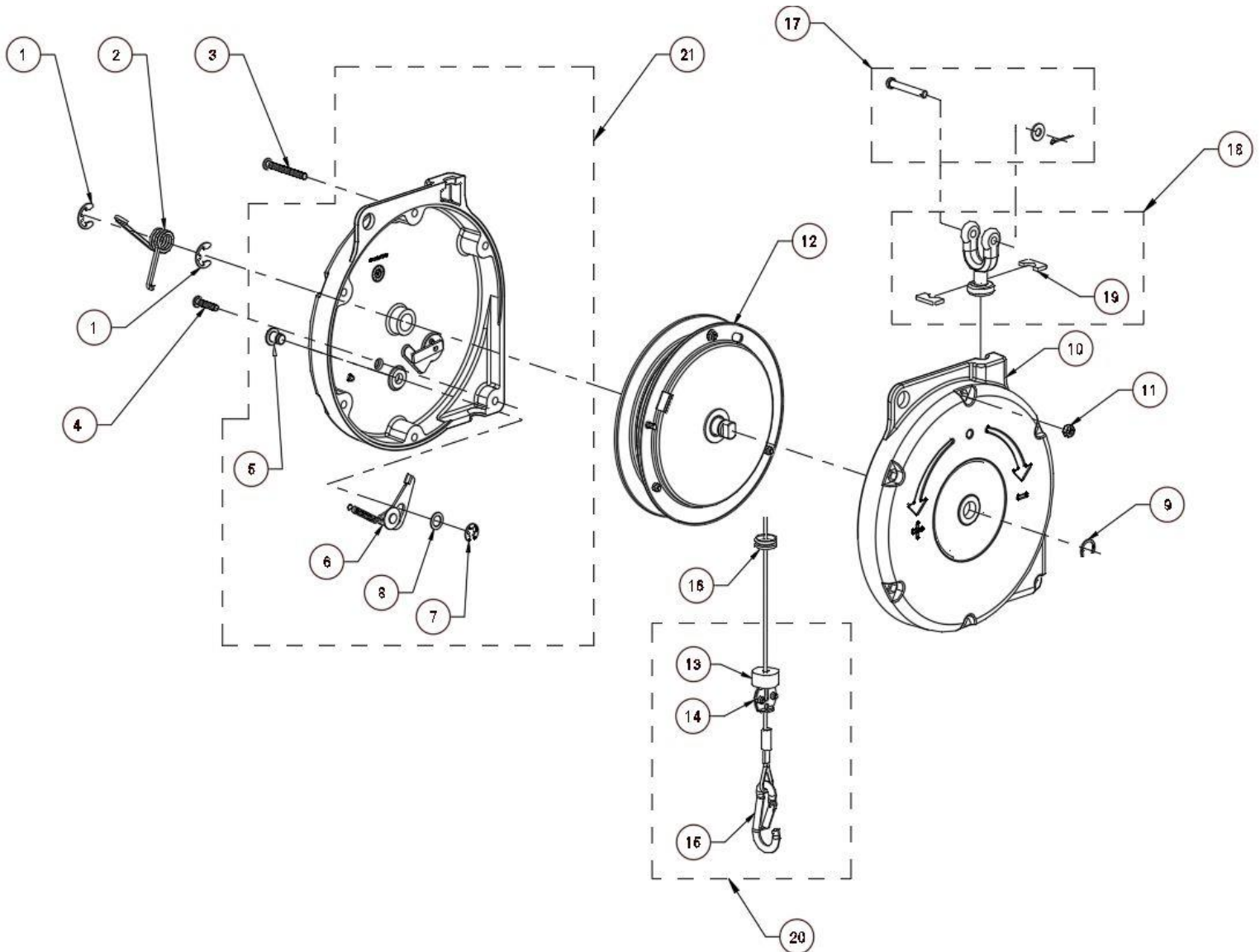

REPAIR PARTS

Item	Part Number	Qty	Part Number Description:
1	AG10310-RP	2	RP - CIRCLIP - TYPE "E" - 5/8 SHAFT - F SERIES
2	9616UK-RP	1	RP - TENSION LOCK SPRING - F SERIES
3	AG17797-RP	5	RP - SCREW - BUTTON HEAD CAP - THREAD [M6]
4	AG17795-RP	1	RP - SCREW - BUTTON HEAD CAP -THREAD [M6-1]xLG[25]
5	M23530005-RP	1	RP - MOUNT SHAFT - SCROLL LOCK - FLRC SERIE
6	9674-2-RP	1	RP - SCROL LOCK LEVER ASEMBLY - F SERIES
7	580-P-30-RP	1	RP - EXTERNAL RETAINING RING - 3/8 SHAFT - F SERIE
8	AG18769-RP	1	RP - SHIM WASHER - TK[0.5mm] - BZP - F & JK SERIES
9	580-P-35-RP	1	RP - EXTERNAL RETAINING RING - 5/8 SHAFT - F SERIE
10	M6501-HP-1-RP	1	RP - HOUSING FRONT SIDE - POWDER - BLUE - FLRC
11	AG17800-RP	6	RP - NUT - NYLOC - THREAD [M6 x 1] x TK[6.0mm]
12	H4211-5-RP	1	RP - SPRING CASSETTE & SHAFT ASSY- 5FLRC
	H4211-10-RP	1	RP - SPRING CASSETTE & SHAFT ASSY-10FLRC
	H4211-15-RP	1	RP - SPRING CASSETTE & SHAFT ASSY-15FLRC
	H4211-22-RP	1	RP - SPRING CASSETTE & SHAFT ASSY-22FLRC
13	10031-RP	1	RP - RUBBER SHOCK ABSORBER - F SERIES
14	9833-RP	1	RP - CABLE STOP ASSEMBLY - F & BF SERIES
15	1146-P-15-RP	1	RP - CARABINER HOOK with LATCH - 6 x 60 MM
16	13613-RP	1	RP - STEEL CABLE GUIDE - F & FLRC SERIE
17	H18110017	1	KIT- CLEVIS & COTTER - RF & BF & FLRC SERIES
18	H16510014	1	KIT - UPPER SWIVEL ASSEMBLY- BF & FLRC SERIE
19	M83010022-RP	1	RP - THRUST WASHER - UPPER MOUNT - BF & FLRC
20	CBRP-22F-8	1	RP - REPLACEMENT CABLE - [8FT][2.5M] - F SERIE
21	H2252-2-RP	1	RP - HSNG & RATCHET LOCK ASSY - NEW - FLRC SERIE

Aero-Motive GmbH

Grünwalder Weg 30
82041 Oberhaching
Germany

Phone: +49 89 55875-700

Web Site

www.aero-motive.com

General Sales

info@aero-motive.com

Technical Support Group

techsupport@aero-motive.com